

DIMENSIONI D'INGOMBRO - OVERALL DIMENSIONS

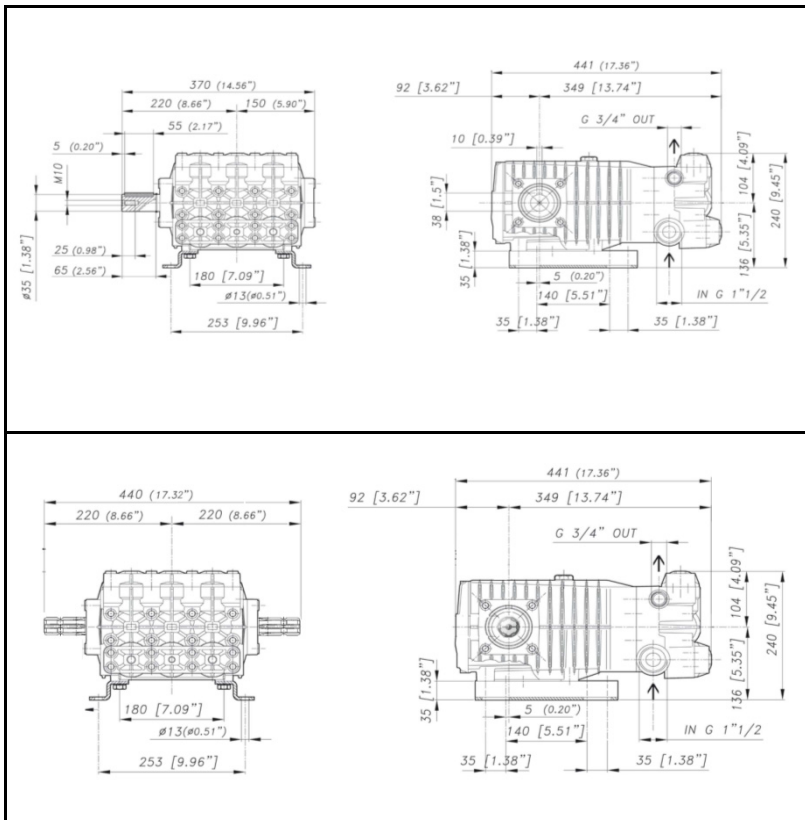

ALBERO POMPA - PUMP SHAFT

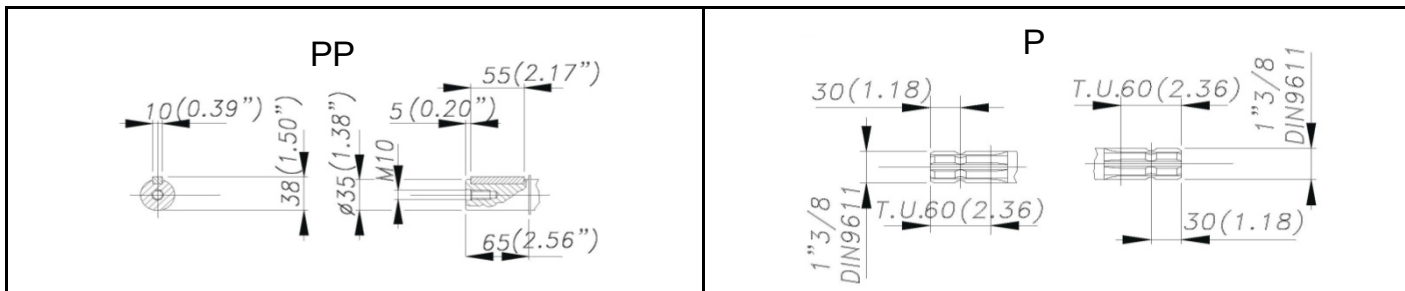

COPPIA DI SERRAGGIO - TORQUE CHART

CODICE - CODE	Q.TY	POS	N-m	Lbr.ft
86.3910.00.2	16	4	68	50,2
86.4120.00.2	8	5	68	50,2
86.3703.00.2	4	28	68	50,2
86.3696.00.2	8	32	40	29,6
86.2216.00.2	10	43	10	7,4
86.3439.00.2	6	44	40	29,5
86.4091.00.2	3	63	50 (LOXEAL 55-14)	36,9 (LOXEAL 55-14)
84.3898.00.2	3	62	LOXEAL 55-14	LOXEAL 55-14

Tolleranza di serraggio: 0/-10%
Tolerance on torque value: 0/-10%

INFORMAZIONI UTILI USEFUL INFORMATION

LUBRIFICANTE - LUBRICANT:
OLIO MOTORE O SEMIIDRAULICO SAE 30
MOTOR OIL OR SEMI-HYDRAULIC OIL SAE 30



CKA 150 P - CKA 150 PP

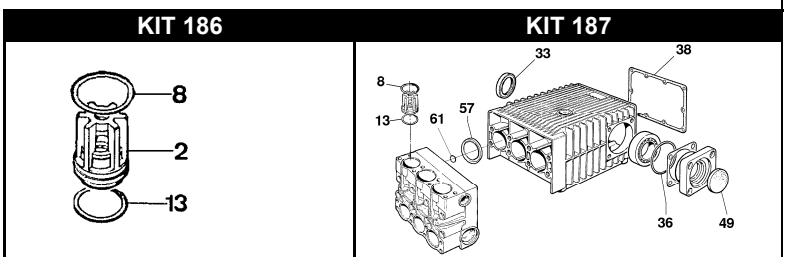
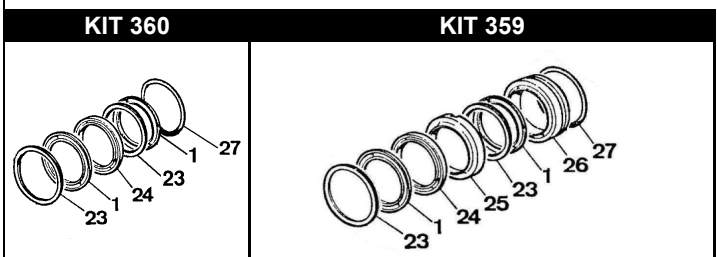
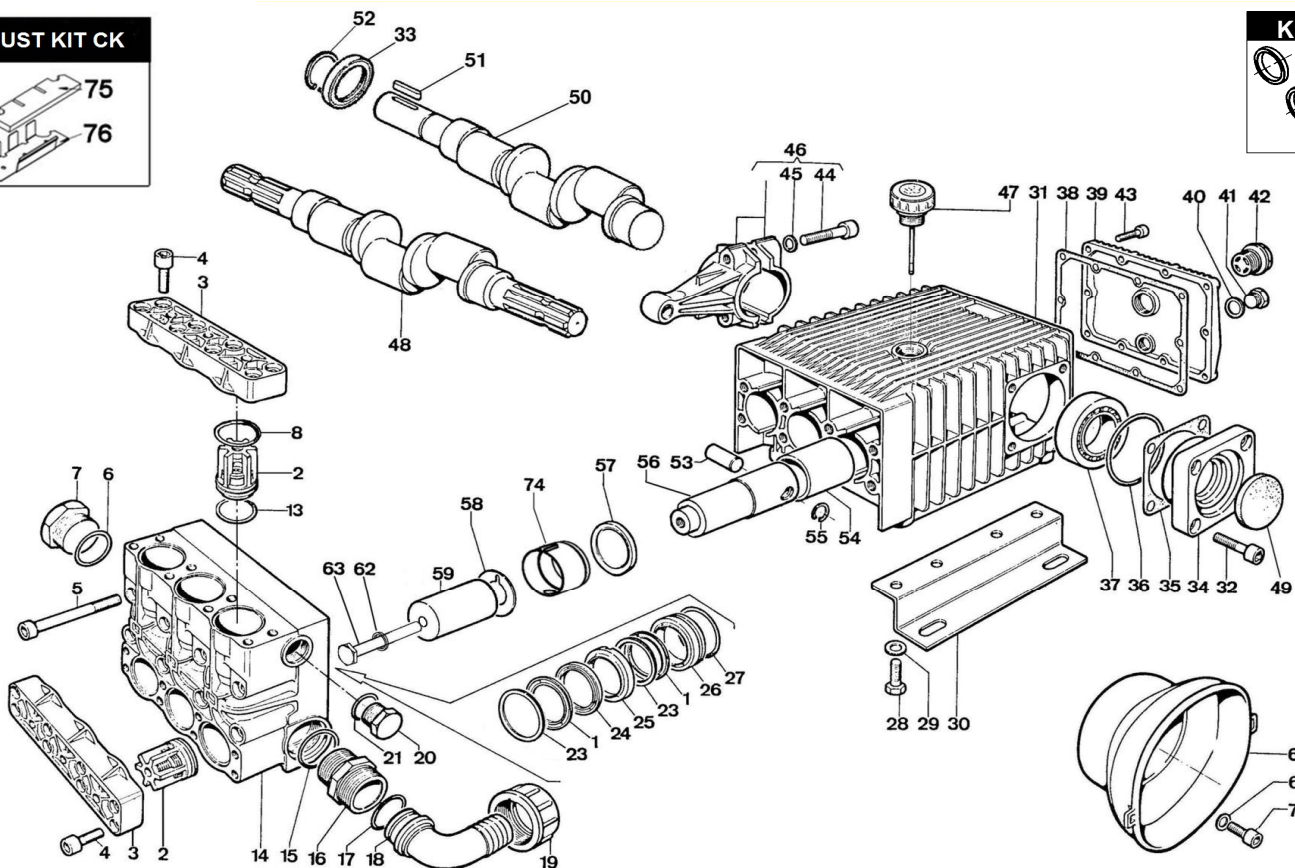
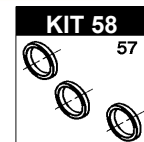
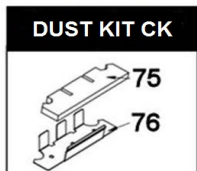

POS.	CODICE PART NO. RÉF.	DENOMINAZIONE - DESCRIPTION - DESCRIPTION	Q.TY
1	KIT 359-360	802232002 V PACKING DIA. 50X60	6
2	KIT 186	739824973 VALVES ASSY	6
3		730416092 VALVES COVER	2
4		863910002 BOLT TCEI M12x40 UNI5931	16
5		864120002 BOLT TCEI M12x110 UNI5931	8
6		803265002 O-RING	1
7		852752002 CAP G. 1"1/2	1
8	KIT 186-187	803270002 O-RING 3,53x49,2	6
13	KIT 186-187	803253002 O-RING 3,53x34,52	6
14		730761092 PUMP HEAD	1
15		803265002 O-RING	1
16		835092502 NIPPLE G. 1"1/2-G. 1"3/4	1
17		803208502 O-RING 2,62x37,77	1
18		840595002 90° ELBOW CONNECTOR DIA.40 - 1,57"	1
19		820095002 WING NUT G. 1"3/4	1
20		852693532 CAP G. 3/4	1
21		803218002 O-RING 3x22	1
23	KIT 359-360	730047322 THRUST RING	6
24	KIT 359-360	730767322 ANTI-EXTRUSION RING	3
25	KIT 359	730769532 FRONT GLAND 50x60	3
26	KIT 359	730768532 REAR GLAND 50x60	3
27	KIT 359-360	803283002 O-RING 3,53x58,74	3
28		863703002 BOLT M12X25 UNI5739	6
29		843844002 WASHER D.13 UNI11751	6
30		730024612 MOUNTING RAIL	2
31		730506092 CRANKCASE	1
32		863696002 BOLT TCEI M12x25 UNI5931	8
33	KIT-187	802143002 OIL SEAL	2-1
34		730477092 BEARING COVER D.80	2
35/1		730413652 SHIM SP.0,1	1
35/2		730414652 SHIM SP.0,2	1
36	KIT-187	803210672 O-RING 2,62x88,57	2
37		812940002 BEARING 45X80X26	2
38	KIT-187	730065722 COVER GASKET	1
39		730475092 CRANKCASE COVER	1
40		824107002 GASKET D.16,5x23x1	1
41		852579532 CAP G.3/8	1

POS.	CODICE PART NO. RÉF.	DENOMINAZIONE - DESCRIPTION - DESCRIPTION	Q.TY
42		853515502 OIL SIGHT GLASS WITH O-RING	1
43		862216002 BOLT TCEI M6x25 UNI5931	10
44		863439002 BOLT TCEI M10x45 UNI5931	6
45		843870002 SCHNORR WASHER D.10,5	6
46		739802972 CONROD	3
47		853516002 OIL PLUG + DIP STICK	1
48		730367262 CRANKSHAFT CKA 150 P	1
49	KIT-187	802099602 CAP D.52x7	1
50		730364262 CRANKSHAFT CKA 150 PP	1
51		806585002 TAB 10x8x55	1
52		801264002 SNAP RING D.35	1
53		852007402 PISTON PIN DIA.18x35	3
54		804470002 BUSHING	3
55		800040002 SNAP RING D.18	6
56		730485512 PISTON GUIDE	3
57	KIT 58-187	802180102 OIL SEAL	3
58		844212002 WASHER	3
59		730550182 CERAMIC PISTON D.50	3
62		843898002 COPPER WASHER D. 12X20X1,5	3
63		864091002 PISTON BOLT M12X100 UNI5737	3
68		311482322 PLAIN SAFETY CONE (OPTIONAL)	1
69		843710002 WASHER DIA.9X24X2 UNI 6593 (OPTIONAL)	2
70		862475002 BOLT M8X14 UNI 5931 (OPTIONAL)	2
74		730528322 OIL SEAL SPACER	3
75	DUST KIT	730531722 DUST SHEET	1
76	DUST KIT	730531612 DUST FILTER	1

REPAIR KIT	ITEM NO.s INCLUDED	DENOMINAZIONE - DESCRIPTION - DESCRIPTION	PCS.
KIT 58	739842973	SPARE PARTS KIT	3
KIT 186	739871973	SPARE PARTS KIT	18
KIT 187	731028973	SPARE PARTS KIT	24
KIT 359	739939973	SPARE PARTS KIT	24
KIT 360	739940973	SPARE PARTS KIT	18
DUST KIT CK	730531973	SPARE PARTS KIT	2

