

## DIMENSIONI D'INGOMBRO - OVERALL DIMENSIONS

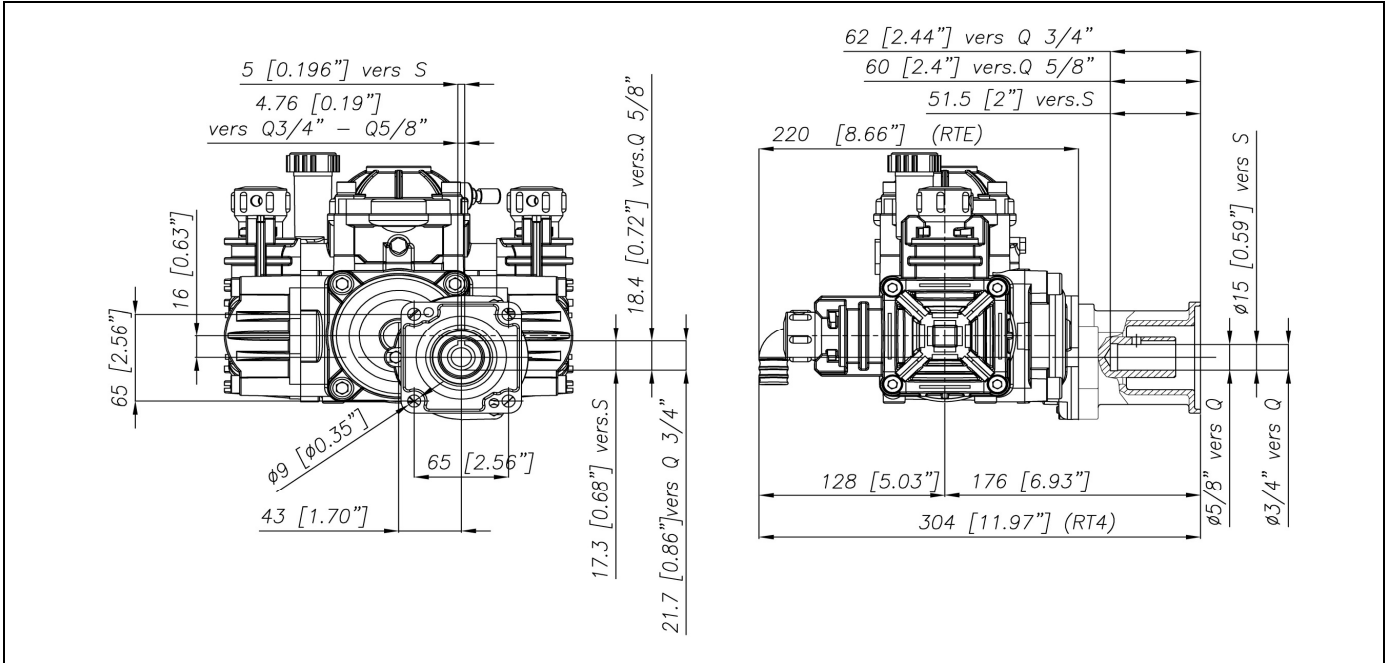

ALBERO POMPA - PUMP SHAFT

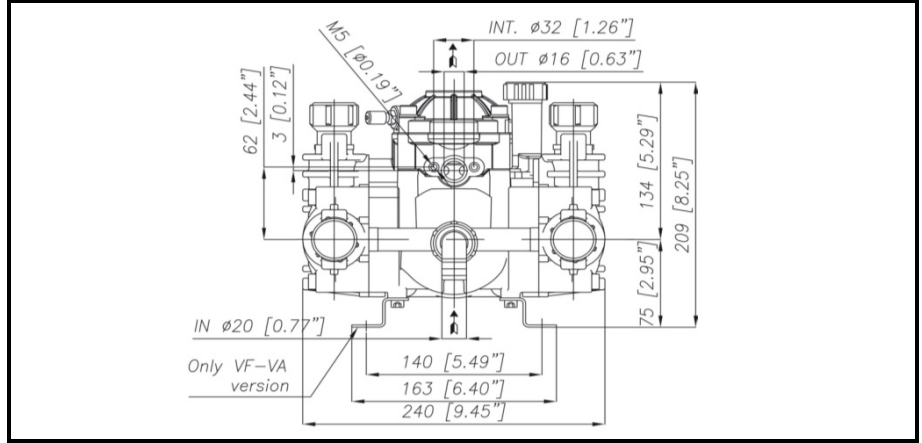

COPPIA DI SERRAGGIO - TORQUE CHART					
CODICE - CODE	Q.TY	POS	N-m	Lbr.ft	
86.2900.00.2	8	7	10	7,4	
03.0021.97.3	2	12	5	3,7	
86.1605.00.2	1	17	5	3,7	
86.2945.00.2	2	21	10	7,4	
86.2951.00.2	2	24	10	7,4	
863.300.00.2	4	36	40	29,5	
86.2301.00.2	2	47	10	7,4	
83.8012.00.2	1	52	10	7,4	
86.2260.00.2	2	53	10	7,4	
86.2108.00.2	2	56	10	7,4	
81.4545.00.2	3-5	61	10	7,4	

Tolleranza di serraggio - Tolerance on torque value: 0/-10%

INFORMAZIONI UTILI USEFUL INFORMATION				
LUBRIFICANTE- LUBRICANT:				
<b>POMPA - PUMP:</b> OLIO MOTORE O SEMIIDRAULICO SAE 30 MOTOR OIL OR SEMI-HYDRAULIC OIL SAE 30				
<b>PRESSIONE ACCUMULATORE ACCUMULATOR PRESSURE</b>				
<b>PRESSIONE DI LAVORO - OPERATING PRESSURE</b>	2 + 5	5+10	10 + 20	20 + 50
<b>ACCUMULATORE ACCUMULATOR</b>	2	2 + 5	5 + 7	6 + 8

## KIT MEMBRANE - DIAPHRAGMS KIT

KIT	94.9871.97.3	BUNA - N			94.9910.97.3	VITON				94.9917.97.3	PRE-SET DESMOPAN				94.9917.97.3DS	PRE-SET DURAMAX			
		1	18	10		15	1	18	10		15	4	6	1		18	10	15	4
<b>POSIZIONE ESPLOSO POSITION NUMBER</b>																			
<b>QUANTITA' NEL KIT QUANTITIES INCLUDED</b>	2	1	4		2	1	4	4		2	1	4	4		2	1	4	4	

## KIT POMPA/KIT VALVOLE - PUMP KIT/VALVES KIT

KIT	94.9942.97.3	KIT POMPA PUMP KIT							94.9888.97.3	KIT VALVOLE VALVE KIT								
		10	15	6	4	22	30	35		2	5							
<b>POSIZIONE ESPLOSO POSITION NUMBER</b>																		
<b>QUANTITA' NEL KIT QUANTITIES INCLUDED</b>	2	4	2	2	1	1	1		4	4								

# POLY 2025 RTE.1-RT4.1

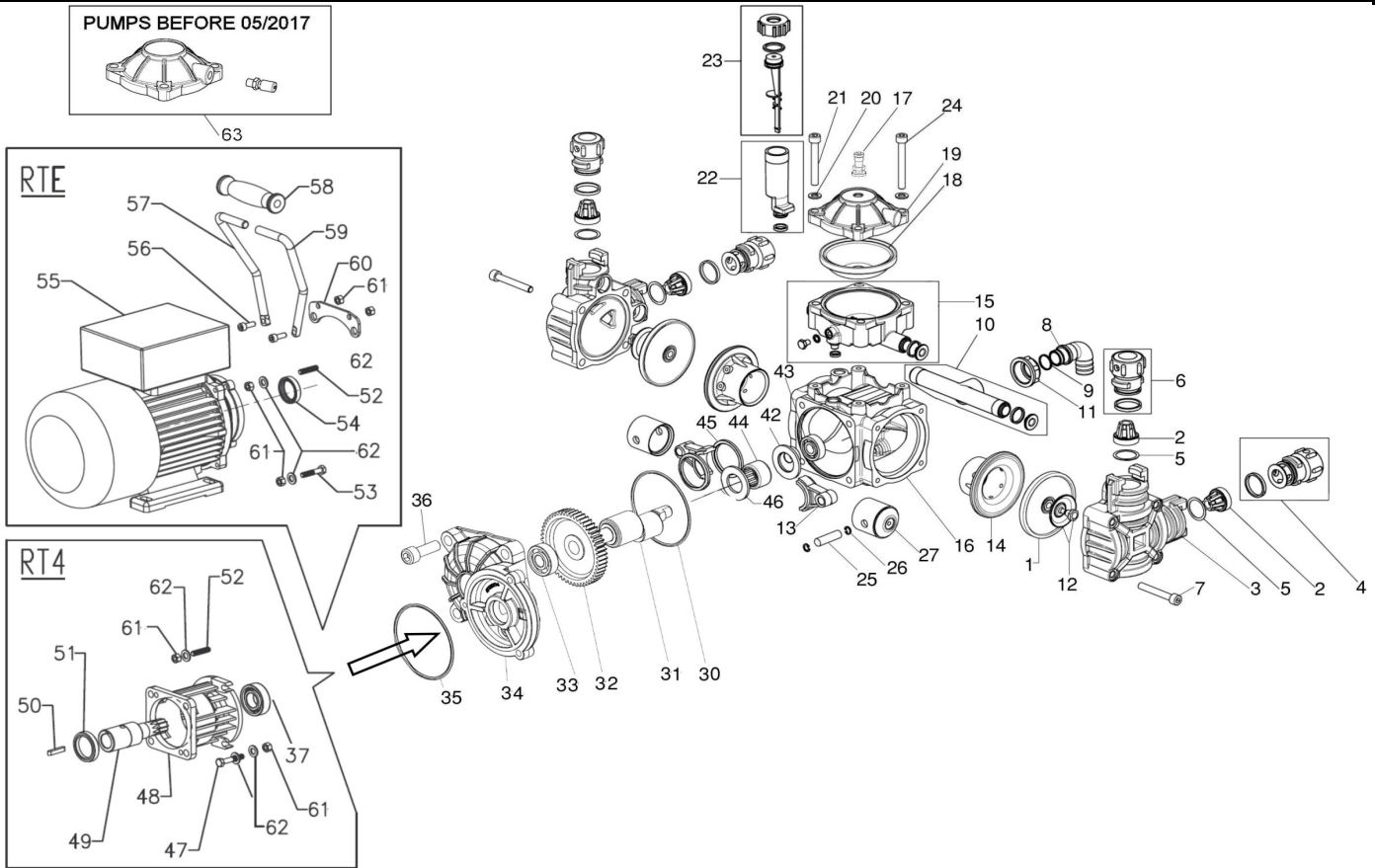

POS.	CODICE PART NO. REF.	DENOMINAZIONE - DESCRIPTION - DESCRIPTION	Q.TY	POS.	CODICE PART NO. REF.	DENOMINAZIONE - DESCRIPTION - DESCRIPTION	Q.TY
1	94.0040.31.2	PISTON DIAPHRAGM	2	32	94.0400.42.2	GEAR Z=48	1
1	94.0042.00.2DS	PRE-SET DURAMAX PISTON DIAPHRAGM	2	33	81.2522.00.2	BALL BEARING	1
1	94.0042.00.2	PRE-SET DESMOPAN PISTON DIAPHRAGM	2	34	94.0383.09.2	CRANKCASE	1
1	94.0040.33.2	VITON PISTON DIAPHRAGM	2	35	80.3210.64.2	O-RING 2.62X75.87	1
2	94.9828.97.3	VALVE ASSY	4	36	86.3300.00.2	SCREW M10X30 UNI 5931	4
3	94.0302.32.2	PUMP HEAD	2	37	81.2631.00.2	BALL BEARING	1
4	94.9869.97.3	KIT INLET CAP	2	42	94.0026.32.2	SPACER	1
5	82.4154.50.2	GASKET	4	43	81.2522.00.2	BALL BEARING	1
6	94.9878.97.3	KIT OUTLET CAP	2	44	81.2688.00.2	BEARING	1
7	86.2900.00.2	SCREW TCEI M8x55	8	45	94.0047.76.2	CONROD RING	2
8	84.0521.00.2	SUCTION CONNECTOR DIA.20-0,78"	1	46	94.0027.32.2	SPACER	1
9	80.3060.50.2	O-RING 1.78x12.42	1	47	86.2301.00.2	SCREW M6X35 UNI 5737	2
10	94.9868.97.3	KIT INLET MANIFOLD	1	48	94.0210.09.2	MOTOR FLANGE	1
11	82.0042.10.2	WING NUT G.3/4	1	49	94.0403.42.2A	PINION Z=9 (D.3/4")	1
12	03.0021.97.3	KIT DIAPHRAGM WASHER/SCREW AISI 316	2	49	94.0401.42.2A	PINION Z=9 (D.15)	1
13	94.0008.09.2	CONROD	2	49	94.0402.42.2A	PINION Z=9 (D.5/8")	1
14	94.0015.01.2	PISTON SLEEVE	2	50	80.6436.05.2	TAB 4,75X5X35 (D.3/4"D.5/8")	1
15	94.9867.97.3	KIT DAMPER BODY	1	50	80.6445.05.2	TAB 5X5X35 (D.15)	1
16	94.0301.09.2	CRANKCASE	1	51	80.2117.50.2	OIL SEAL 30X40X7 VITON	1
17	86.1606.00.2	AIR VALVE (FROM 05/2017)	1	52	83.8012.00.2	STUD M6X18 UNI5911	1
18	94.0041.31.2	DAMPER DIAPHRAGM	1	53	86.2260.00.2	SCREW M6X30 UNI 5737	2
18	94.0041.33.2	VITON DAMPER DIAPHRAGM (OPT.)	1	54	80.2072.00.2	OIL SEAL 20X35X7	1
19	94.0003.09.2	DAMPER COVER	1	55	83.2081.70.2	ELECTRIC MOTOR 230V (Z=9)	1
20	84.3685.00.2	WASHER DIA.8,4x15x1,5	4	55	83.2081.80.2	ELECTRIC MOTOR 400V (Z=9)	1
21	86.2945.00.2	SCREW TCEI M 8X60 UNI5931	2	56	86.2108.00.2	SCREW TCEI M6X16 UNI5931	2
22	94.9866.97.3	KIT OIL FILLER	1	57	31.1324.61.2	LEFT HALF HANDLE	1
23	94.9855.97.3	KIT ROP OIL INDICATOR	1	58	82.8410.00.2	KNOB	1
24	86.2951.00.2	SCREW TCEI M8X65 UNI5931	2	59	31.1325.61.2	RIGHT HALF HANDLE	1
25	85.2006.00.2	PISTON PIN	2	60	94.0404.61.2	BRACKET	1
26	80.0003.00.2	SNAP RING DIA.10	4	61	81.4545.00.2	NUT M6 UNI5587	3-5
27	94.0016.08.2	PISTON POLY 2020	2	62	84.3585.00.2	WASHER D.6 UNI6592	5
30	80.3080.90.2	O-RING OR 1,78X82,27	1	63	94.9946.97.3	BALLASTER KIT	1
31	94.0384.26.2	SHAFT	1				